

# EPIK Series

1500~4000 Ton (large tonnage)

- Feature**
- Injection Molding Machine : 1500~4000Ton
  - Servo Motor Axis : Max. 7 axis
  - Motion Guide : High Strength and Low noise LM
  - Crosswise Frame : Double Support Type
  - Vertical Arm Structure : Telescopic Arm(2 step)
  - Controller : Body Attached Controller
  - All Axis : Digital Servo Motor

Power : 1Phase/3Phase AC220V(50/60Hz)  
 Driving Method : Digital Servo Motor  
 Control Method : Micro Computer  
 Air Pressure : 6 kgf/cm<sup>2</sup>  
 Max. Air Pressure : 8 kgf/cm<sup>2</sup>  
 Chuck Rotation : 90°

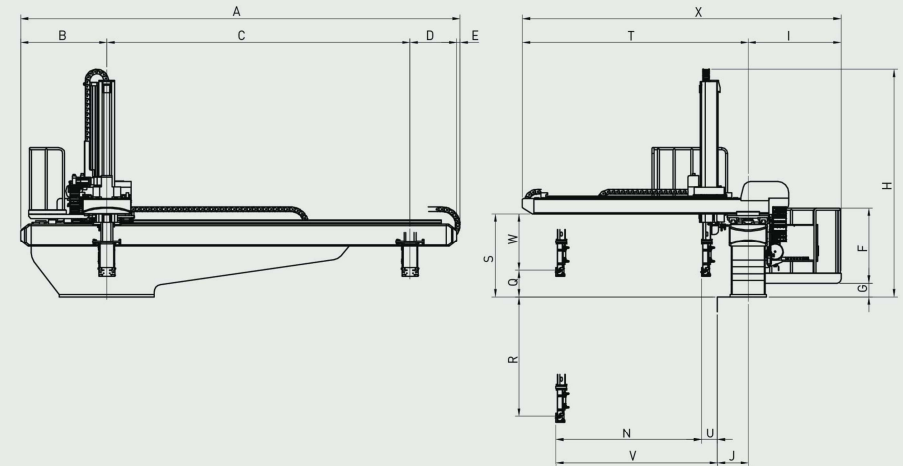

## Technical Specification

Model	Traverse (mm)		Vertical (mm)	Crosswise (mm)	Max. Electric Consumption	Air Consumption [ℓ(normal)/Cycle]	Max. Payload (Chuck Included)	I.M.M (Ton)
	Standard	L-Type						
EPIK-2000S	3500	4000	2100	1680	3Phase / AC 220V S : 11.4A	54	40kgf	1500~2000
EPIK-2500S	4000	4500	2500	1900	3Phase / AC 220V S : 16.7A	92	50kgf	2000~2500
EPIK-3000S	4000	4500	3000	2240	3Phase / AC 220V S : 20.6A	100	80kgf	2000~4000
EPIK-4000S	4500	5000	3500	2240	3Phase / AC 220V S : 20.6A	100	100kgf	2000~4000

All information subject to change without notice for quality improvements.

## Dimension

Unit : mm / ( )mark signify LType.

Model	A	B	C	D	E	F	G	H	I	J	N	T	Q	R	S	U	V	W	X
EPIK-2000S	5015 (5515)	963	3500 (4000)	553	-	1194	160	2781	1175	290	1680	2676	300	1800	1092	286	1966	792	3851
EPIK-2500S	5821 (6321)	1135	4000 (4500)	615	72	1194	180	3009	1225	340	1900	2977	325	2175	1101	289	2189	776	4202
EPIK-3000S	5899 (6399)	1068	4000 (4500)	628	203	1194	230	3549	1275	385	2240	3605	417	2583	1257	377	2617	840	4880

All information subject to change without notice for quality improvements.