

EPIK-V Series

100~1300 Ton (for automation / high-precision type)

Power : 1Phase/3Phase AC220V(50/60Hz)
 Driving Method : Digital Servo Motor
 Control Method : Micro Computer
 Air Pressure : 6 kgf/cm²
 Max. Air Pressure : 8 kgf/cm²
 Chuck Rotation : 90°

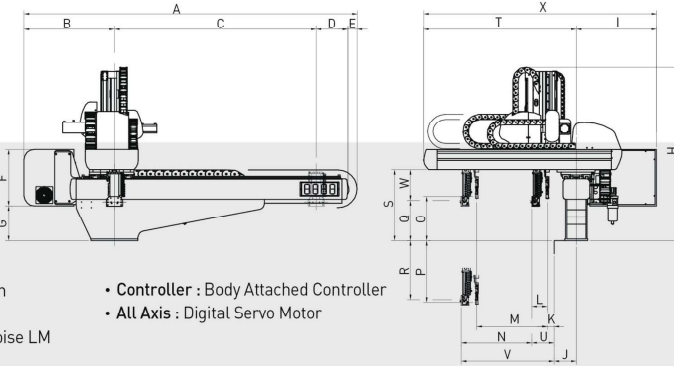

Feature

- Injection Molding Machine : 100~1300Ton
- Servo Motor Axis : Max. 7 axis
- Motion Guide : High Strength and Low noise LM
- Crosswise Frame : Double Support Type
- Vertical Arm Structure : Telescopic Arm(2 step)
- Controller : Body Attached Controller
- All Axis : Digital Servo Motor

Dimension

Unit : mm / () mark signify L Type, [] mark signify LL type.

Model	A	B	C	D	E	F	G	H	I	J	K	L	M	N	O	P	Q	R	S	T	U	V	W	X	
EPIK-V-200S	2557 (2757)	745	1500 (1700)	275	37	400	280	1318	556	165	-	-	-	634	-	-	286	514	530	1135	52	686	244	1691	
EPIK-V-200D	[2957]		[1900]								62	124	500	500	346	504					186				
EPIK-V-300S	2557 (2757)	745	1500 (1700)	275	37	400	280	1397	556	165	-	-	-	814	-	-	286	664	530	1315	52	866	244	1871	
EPIK-V-300D	[2957]		[1900]								62	124	680	680	346	604					186				
EPIK-V-400S	2780 (3080)	785	1700 (2000)	295	-	400	314	1668	581	205	-	-	-	1050	-	-	258	842	632	1626	51	1106	374	2207	
EPIK-V-400D											86	170	850	850	340	760					256				
EPIK-V-600S	3120 (3620)	785	2000 (2500)	335	-	400	444	1908	606	235	-	-	-	1085	-	-	291	1009	753	1719	98	1183	462	2325	
EPIK-V-600D											72	237	875	875	347	953					308				
EPIK-V-800S	3705 (4205)	825	2500 (3000)	380	-	500	485	2331	811	255	-	-	-	1160	-	-	368	1232	927	1873	127	1287	559	2684	
EPIK-V-800D											69	259	960	960	428	1172					327				
EPIK-V-1300S	4502 (5002)	963	3000 (3500)	523	17	-	-	2657	866	290	-	-	-	1550	-	-	361	1439	1092	2546	286	1836	731	3412	
EPIK-V-1300D											85	341	1410	1410	397	1403					426				

Technical Specification

() is optional.

Model	Traverse (mm)			Vertical (mm)		Crosswise (mm)		Max. Electric Consumption	Air Consumption [(normal)/Cycle]	Max. Payload (Chuck Included)	I.M.M (Ton)
	Standard	L-Type	LL-Type	Main Arm	Sub Arm	Main Arm	Sub Arm				
EPIK-V-200S						634	-	1 Phase / AC 220V S: 11.6A / D: 15.7A	7	8 Kgf	100~250
EPIK-V-200D	1500	1700	1900	800(950)		850(950)	500				
EPIK-V-300S						814	-	1 Phase / AC 220V S: 11.6A / D: 15.7A	7	8 Kgf	180~300
EPIK-V-300D	1500	1700	1900	950		950	680				
EPIK-V-400S						1050	-	1 Phase / AC 220V S: 11.6A / D: 15.7A	16	10 Kgf	280~450
EPIK-V-400D	1700	2000	-	1100		1100	850				
EPIK-V-600S						1085	-	1 Phase / AC 220V S: 11.6A / D: 15.7A	22	15 Kgf	400~650
EPIK-V-600D	2000	2500	-	1300		1300	875				
EPIK-V-800S						1160	-	3 Phase / AC 220V S: 8.5A / D: 10.8A	35	20 Kgf	550~900
EPIK-V-800D	2500	3000	-	1600		1600	960				
EPIK-V-1300S						1550	-	3 Phase / AC 220V S: 11.4A / D: 15.2A	56	30 Kgf	1000~1300
EPIK-V-1300D	3000	3500	-	1800		1800	1410				

All information subject to change without notice for quality improvements.

EPIK-E Series

400~2000 Ton (Slim type)

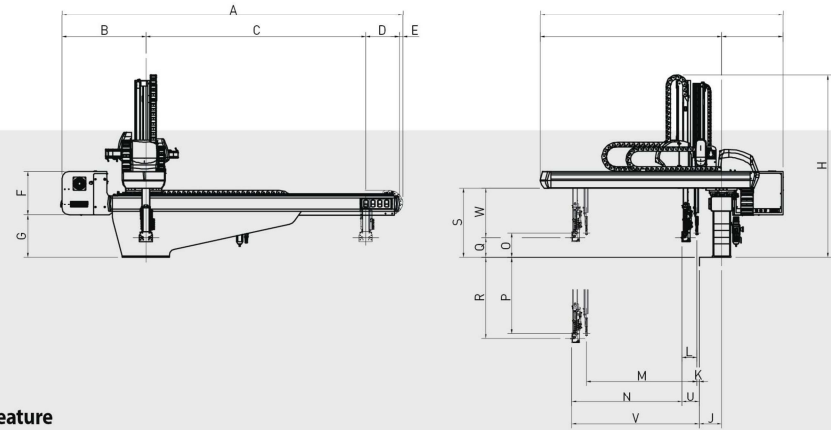

Feature

- Injection Molding Machine : 400~2000Ton
- Servo Motor Axis : Max. 7 axis
- Motion Guide : High Strength and Low noise LM
- Crosswise Frame : Double Support Type
- Vertical Arm Structure : Telescopic Arm(2 step)
- Controller : Body Attached Controller
- All Axis : Digital Servo Motor

Power : 1Phase/3Phase AC220V(50/60Hz)
 Driving Method : Digital Servo Motor
 Control Method : Micro Computer
 Air Pressure : 6 kgf/cm²
 Max. Air Pressure : 8 kgf/cm²
 Chuck Rotation : 90°

Dimension

Unit : mm / () mark signify L Type.

Model	A	B	C	D	E	F	G	H	I	J	K	L	M	N	O	P	Q	R	S	T	U	V	W	X	
EPIK-E-600S	3102	765	2000	305	32	400	382	1662	556	205	-	-	-	1110	-	-	178	1122	632	1653	52	1162	454	2209	
EPIK-E-600D											22	135	1005	1005	221	1079					157				
EPIK-E-800S	3580	785	2500	295	-	400	314	1955	581	235	-	-	-	1150	-	-	81	1519	632	1806	98	1248	550	2387	
EPIK-E-800D											57	173	1019	1019	126	1474					230				
EPIK-E-1300S	4145	770	3000	375	-	400	444	2199	606	255	-	-	-	1585	-	-	139	1662	753	2259	122	1707	615	2865	
EPIK-E-2000S	4765	825	3500	440	-	400	545	2593	631	290	-	-	-	1640	-	-	179	1921	927	2548	287	1927	748	3179	
EPIK-E-2500S	5505	963	4000	543	31	400	525	3025	786	325	-	-	-	1800	-	-	300	2200	1092	2796	258	2058	792	3582	
EPIK-E-3000S	5749	1135	4000	615	71	400	674	3450	836	375	-	-	-	2000	-	-	418	2583	1238	3087	279	2279	821	3923	

Technical Specification

() is optional.

Model	Traverse (mm)	Vertical (mm)		Crosswise (mm)		Max. Electric Consumption	Air Consumption [(normal)/Cycle]	Max. Payload (Chuck Included)	I.M.M (Ton)
		Main Arm	Sub Arm	Main Arm	Sub Arm				
EPIK-E-600S				1110	-	1 Phase / AC 220V S: 11.6A / D: 15.7A	16	10 Kgf	400~650
EPIK-E-600D	2000	1300(1500)		1005	1005				
EPIK-E-800S				1150	-	1 Phase / AC 220V S: 11.6A / D: 15.7A	22	15 Kgf	550~900
EPIK-E-800D	2500	1600(1800)		1019	1019				
EPIK-E-1300S	3000	1800		1585	-	1 Phase / AC 220V 11.6A	25	18 Kgf	1000~1300
EPIK-E-2000S	3500	2100		1640	-	3 Phase / AC 220V 8.5A	38	30 Kgf	1500~2000
EPIK-E-2500S	4000	2500		1800	-	3 Phase / AC 220V 16.7A	54	50 Kgf	2000~2500
EPIK-E-3000S	4000	3000		2000	-	3 Phase / AC 220V 20.6A	140	65 Kgf	2000~4000

All information subject to change without notice for quality improvements.